

BMW Z4 M Coupé
BMW Z4 M Roadster



Sheer
Driving Pleasure





The shape of
thrills to come.

Amidst the urban sprawl,
one face etched in the memory.



How much adrenaline
can you take?



Take your pulse for a spin.
Up to 8000 rpm.



8000 rpm

5200 rpm

5500 rpm

5900 rpm

6500 rpm

Shift down.
Blast off.

8000 rpm

7200 rpm

6500 rpm

5900 rpm

5500 rpm

8000 rpm





7700 rpm

8000 rpm

7500 rpm

7200 rpm

6900 rpm

Many forces are at work
in a bend. The greatest
bears the letter "M".



The cockpit has one central instrument. Your intuition.



An “M” says more than a thousand words.

1. Door sill trim with M logo.
2. Info Display with white-illuminated speedometer and rev counter scales with variable pre-warning field and red-illuminated needles.
3. M light-alloy wheels: double-spoke 224 M.
4. Two dual tailpipes in chromed stainless steel.
5. Illuminated gear lever.
6. Multifunction M leather steering wheel.



■ Standard equipment □ Optional equipment — Not available

Safety	Z4 M Roadster	Z4 M Coupé
Airbags:		
– Driver and front passenger airbags, seat occupancy detector for front passenger airbag	■	■
– Side airbags for driver and front passenger	■	■
Alarm system	□	□
Brake force display	■	■
Brake light, third	■	■
Bumper system with replaceable deformation zones front and rear (for impacts up to 15 km/h); regenerating deformation elements at the front absorb impacts of up to 4 km/h without damage	■	■
Central locking , locks doors, boot lid, fuel filler cap, storage compartment at the back between the seats, and soft-top (Z4 M Roadster)	■	■
Child seat fastening , ISOFIX, on passenger seat (with airbag deactivation)	□	□
Compound high-performance brakes , 18-inch, floating-mounted, inner-vented front and rear	■	■
Dynamic Stability Control (DSC with additional functions, incl. ABS and Brake Assistant)	■	■
Emergency luggage compartment lock release	■	■
Remote control for central locking	■	■
Roll-over safety system	■	—
Safety belts , automatic with belt tensioner	■	■
Side impact protection , integrated	■	■

Exterior design	Z4 M Roadster	Z4 M Coupé
Auxiliary indicator lights in front side panels , integrated into BMW emblem	■	■
Bumpers in body colour	■	■
Exterior door handles in body colour	■	■
Hardtop¹	□	—
Hardtop, preparation	□	—
Headlight surrounds in chrome matt	■	■
Metallic paintwork	□	□
Model designation , deletion (at no extra cost)	□	□
Ornamental front grille with chrome surround and black kidney slats	■	■
Soft top:		
– Black	■	—
– Dark Beige ²	□	—
– Grey ²	□	—
Soft top operation , fully automatic	■	—
White indicator lights	■	■
Windscreen washer nozzles on the bonnet , heated, incl. heated exterior mirrors	■	■

Equipment packages	Z4 M Roadster	Z4 M Coupé
Exterior mirror package , exterior mirror with electric fold-in function	□	□
Smoker package (at no extra cost)	□	□
Storage package incl. cup holders	□	□

Wheels	Z4 M Roadster	Z4 M Coupé
M light-alloy wheels double-spoke 224M with mixed tyres, 18 inch ³	■	■
Flat tyre indicator	■	■
M Mobility System	■	■

■ Standard equipment □ Optional equipment — Not available

Interior design	Z4 M Roadster	Z4 M Coupé
Doorsill trim with M logo	■	■
Interior trims:		
– Brushed Aluminium, Shadow, fine-grain	■	■
– Carbon-look leather, black	□	□
– Fine wood Madeira, red-brown	□	□
Gear lever and handbrake lever covers , leather	■	■
Roofliner in Anthracite	—	■
Storage compartment at the back between the seats approx. eight litres, lockable via central locking (reduced capacity with CD changer, Hi Fi system and/or navigation system)	■	■
Upholstery:		
– Walknappa full leather	□	□
– Walknappa leather	■	■

Transmission and technology	Z4 M Roadster	Z4 M Coupé
6-cylinder in-line petrol engine with 4-valve technology, electronic throttle butterfly control	■	■
6-speed manual transmission	■	■
Central arm rear axle	■	■
Driving Dynamic Control (sport mode)	■	■
Emissions standard EU4	■	■
Exhaust system , double-flow, with two dual circular chromed tailpipes	■	■
Light-alloy cylinder head	■	■
M differential lock	■	■
M Double-VANOS	■	■
M specific hydraulic power steering	■	■
M specific suspension	■	■
Single-joint spring strut front axle	■	■

Driver assistance	Z4 M Roadster	Z4 M Coupé
Cruise control	□	□
Park Distance Control (PDC)	□	□

Light and sight	Z4 M Roadster	Z4 M Coupé
Exterior mirrors in body colour , electrically adjustable, aspheric	■	■
Glass rear window , heated	■	■
Headlight range control , electric	■	■
Interior light, front , centre with delay function	■	■
Interior lights package	■	■
Interior and exterior mirrors , automatic anti-glare	□	□
Interior mirror , automatic anti-glare	□	□
Interior mirror , trapezoid-shaped	■	■
Rain sensor , incl. headlight range control	□	□
Xenon headlights , high and low beam	■	■

¹ Available as Original BMW Accessory.

² At no extra cost.

³ Incl. wheel security bolts

■ Standard equipment □ Optional equipment — Not available

Interior features	Z4 M Roadster	Z4 M Coupé
Automatic air conditioning	■	■
Heat insulation glass, green , front and side windows (Z4 M Coupé: also rear windscreen)	■	■
M leather steering wheel with multifunction	■	■
Seat/seat comfort:		
– M sports seats for driver and passenger	■	■
– Seat adjustment, electric, with memory function for driver's seat	□	□
– Seat heating for driver and passenger	■	■
Steering wheel column , adjustable for reach and height, manually	■	■
Windscreen with green shade band	□	□

Comfort and interior equipment	Z4 M Roadster	Z4 M Coupé
Armrest at the front	■	■
Boot lid opening, electric , via interior push-button or key-integrated remote control	■	■
Glove compartment , lockable	■	■
Luggage compartment light	■	■
Variable soft top storage box	■	—
Warning triangle and first aid kit	■	■
Wind deflector	□	—
Window lifts, electric , with push/pull switches and trap release	■	■

Entertainment, communication and information	Z4 M Roadster	Z4 M Coupé
Instrument panel with circular speedometer and rev counter (with variable pre-warning field) plus fuel and oil temperature gauges	■	■
Navigation systems*:		
– Business, incl. Radio BMW Business (without CD drive), LC display integrated into the radio control panel	□	□
– Professional, incl. Radio BMW Business CD, with fold-out 16:9 screen	□	□
– Professional, with integrated Bluetooth mobile phone preparation (incl. BMW Assist*)	□	□
– TV function for navigation system Professional for analogue and digital broadcasts	□	□
On-board computer	■	■
Preparation for mobile phone with Bluetooth interface (incl. BMW Assist*)	□	□
Radio/audio:		
– 6-disc CD changer	□	□
– HiFi loudspeaker system	□	□
– HiFi system Professional	□	□
– Radio BMW Business CD	■	■
Voice control system	□	□

* Not available in all countries. Please consult your BMW partner.

BMW Recycling.

Your BMW is the product of a comprehensive recycling concept. But what exactly does that mean in practice? It means that all the requirements of recycling are taken into account from the start, in the initial development of a BMW. One example is the choice of materials carefully selected to preserve resources and ensure efficient recycling compatible with the environment. Each BMW is designed and built for simple and economic recycling after its long running life. We have been collecting the know-how required for this purpose ever since 1994 at the unique BMW Recycling and Dismantling Centre (RDC) near Munich. Please contact your BMW partner on all matters regarding your end-of-life vehicle, who will be happy to advise you.

The models illustrated in this brochure show the specifications for the German market. In part, they include optional equipment and accessories not fitted as standard. According to the specific requirements of other markets, alterations in models, standard and optional equipment, as described in this brochure, may occur. For precise information on model features and the exact level of equipment, please contact your BMW partner. Subject to change in design and equipment.

© BMW AG, Munich/Germany. Reproduction, in part or in whole, only with written permission from BMW AG, Munich.

BMW recommends 

Technical data

Weight		Z4 M Roadster	Z4 M Coupé
Unladen EU ¹	kg	1485	1495
Max permissible	kg	1705	1730
Permitted load ¹	kg	295	310
Permitted axle load, front/rear	kg	840/910	855/935

Engine²		Z4 M Roadster	Z4 M Coupé
Cylinders/valves		6/4	6/4
Capacity	cc	3246	3246
Stroke/bore	mm	91.0/87.0	91.0/87.0
Max output/rpm	kW/rpm	252/7900	252/7900
	hp/rpm	343/7900	343/7900
Max torque/rpm	Nm/rpm	365/4900	365/4900
Compression ratio	:1	11.5	11.5

Transmission		Z4 M Roadster	Z4 M Coupé
Standard transmission ratios	I/II:1	4.35/2.50	4.35/2.50
	III/IV:1	1.67/1.23	1.67/1.23
	V/VI/R:1	1.00/0.85/3.93	1.00/0.85/3.93
Rear axle transmission ratio	:1	3.62	3.62

Performance		Z4 M Roadster	Z4 M Coupé
Top speed	km/h	250 ⁴	250 ⁴
Acceleration 0–100 km/h	s	5.0	5.0
Acceleration 0–1000 m	s	23.7	23.7
Acceleration 80–120 km/h in 4th/5th gear (with standard transmission)	s	5.0/6.5	5.0/6.5

Fuel consumption³		Z4 M Roadster	Z4 M Coupé
Urban	l/100 km	18.2	18.2
Extra-urban	l/100 km	8.6	8.6
Combined	l/100 km	12.1	12.1
CO ₂ emissions	g/km	292	292
Tank capacity approx	l	55	55

Wheels		Z4 M Roadster	Z4 M Coupé
Tyre dimensions	F/R	225/45 ZR 18/255/40 ZR 18	225/45 ZR 18/255/40 ZR 18
Wheel dimensions	F/R	8 J x 18/9 J x 18	8 J x 18/9 J x 18
Material		light-alloy	light-alloy

Electrical system		Z4 M Roadster	Z4 M Coupé
Battery capacity	Ah	70	70
Alternator output	A	147	147
	W	2058	2058

BMW Z4 M Roadster

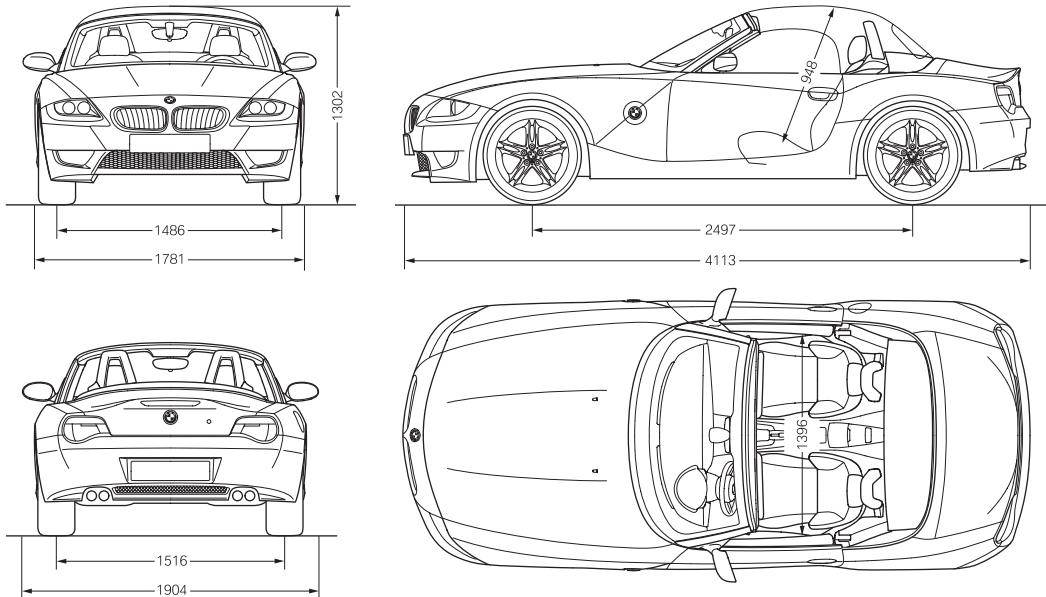

BMW Z4 M Coupé

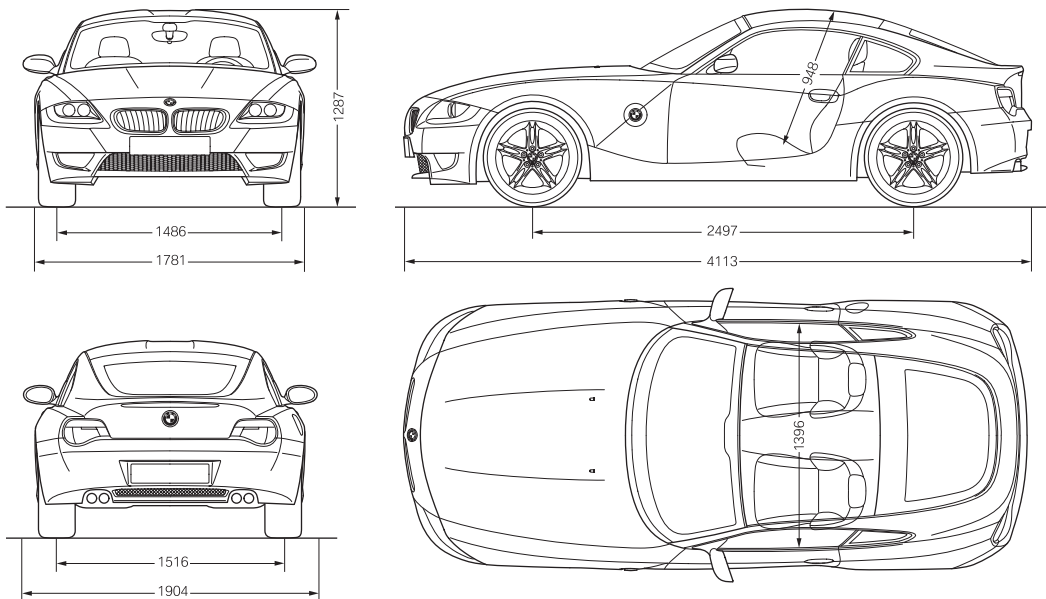

All dimensions in the technical drawings are given in millimetres. Luggage capacity up to 200 – 220 litres on the BMW Z4 M Roadster and 245 – 300 litres on the BMW Z4 M Coupé (VDA measurement).

¹ Figures are based on a 90% fill-up, driver's weight of 68 kg and 7 kg of luggage. Unladen weight applies to vehicles with standard equipment. Optional extras may increase these figures.

² Engine designed for use with RON 98 fuel. Use of RON 95 fuel may result in reduced engine output.

³ Engine conforms to the EU4 emission standard. Fuel consumption is determined according to the ECE combined driving cycle in which approx one third of the distance covered is in urban traffic and two thirds are extra-urban driving. CO₂ emissions are measured in addition to fuel consumption.

⁴ Electronically limited.

More about BMW

www.bmw.com



Sheer
Driving Pleasure

