

BMW X5



Sheer
Driving Pleasure





Driving the new generation of leaders.

Genuine charisma is instantly recognisable.





Built to lead.
Engineered to grip.



Space for high standards and great expectations.



Ahead, the horizon.
All around you, the joys of getting there.



This has gone in.

The pleasure you get from driving a BMW is the result of fine engineering – always setting the benchmark because it is based on much more than engine power. This is the tradition behind BMW EfficientDynamics. It includes the visionary CleanEnergy hydrogen-powered engine, already used in a number of completely emission-free BMW 7 Series saloons. Also going into production soon is the BMW ActiveHybrid – an intelligent, demand-oriented combination of internal combustion engine and electric motor. And every BMW already includes a multi-award-winning BMW EfficientDynamics technology package as standard that boosts dynamics even further whilst simultaneously reducing fuel consumption and CO₂ emissions.

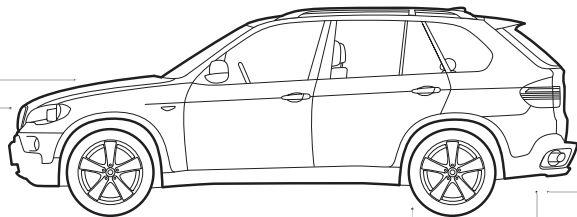

Valvetronic

Valve lift control is fully variable in petrol engines with Valvetronic. The result is improved cold start behaviour and smoother running, as well as a significant drop in fuel consumption.

Air vent control

Engine management signals the engine's current cooling capacity requirements constantly while driving. Rendering a permanent airstream through the radiator unnecessary. The air vents in front of the radiator open or close depending on the environmental temperature and road speed. When shut they improve aerodynamics, shorten the engine's warm-up time and so reduce fuel consumption.

Tyres with reduced rolling-resistance

While driving, tyres are constantly changing shape. This uses up energy and thus fuel. Tyres with reduced rolling-resistance have an improved design and use special materials for their road treads and side walls, thus reducing deformation.

Brake Energy Regeneration

To supply a battery with electrical energy, the generator (alternator) is permanently driven using engine power, which demands additional fuel consumption. Brake Energy Regeneration means the generator usually only generates electricity when the driver either takes the foot off the accelerator or brakes – previously unused kinetic energy is transformed in coasting mode into electrical energy before being fed into the battery. In this way, electricity is generated while coasting, without consuming fuel.

Some BMW EfficientDynamics features are dependent on the car's equipment and are not available for all model variants. Your BMW partner will be happy to provide you with information on all equipment details.

And this is what comes out.

Thanks to the innovative features of EfficientDynamics, BMW has been able to significantly reduce CO₂ emissions in many models. But that's just for starters. We're carrying on our research with EfficientDynamics – in the quest to bring you more driving pleasure and less emissions.

■ Standard equipment □ Optional equipment



□ **Xenon Headlights for high and low beam** incl. automatic headlight range control and headlight washing system, for much better illumination of the road ahead in bad weather, at night or in poor visibility. The four light rings offer a daytime driving light function, and can also be used as parking lights (standard on xDrive48i and xDrive35d).

□ **Adaptive Headlights with variable light distribution**, incl. turning lights, illuminate bends by optimal electromechanical adjustment of the swivelling headlights as soon as the driver turns the steering wheel (only in combination with Xenon lights). The turning light in the fog lights is automatically activated even at a standstill, when the indicator is used or with a steering lock of over ten degrees – up to a speed of 40 km/h.

□ **High-beam assistant** aids the driver at night by automatically switching from high to low beam for oncoming traffic or when street lighting is sufficient.



■ **Fog lights** in free-form technology, integrated in the front air dam, ensure extra safety in poor visibility.



□ **Headlight washing system** provides optimal illumination of the road ahead in all weather conditions. Headlights are automatically cleaned in parallel with the windscreen when the lights are on. (Available in combination with the optional Xenon Headlights).



□ **Roof railing, black, matt:** matched harmoniously to the car's design, the roof railing provides the foundation for BMW's multifunctional roof support for convenient and safe transportation of luggage, bicycles, surfboards, etc.



□ **Roof railing, satin Aluminium:** the roof railing is also available in a satinised aluminium version flush with the roof, to add an individual touch to your BMW X5.



□ **Rain sensor incl. automatic driving lights control:** once activated, the rain sensor automatically switches on the windscreen wipers and controls wiper frequency, depending on how hard it is raining. This feature includes automatic driving lights control switching on the low-beam headlights automatically for example when it gets dark or when entering a tunnel.

■ Standard equipment

□ Optional equipment



■ **Exterior mirrors, electrically adjustable and heated**, upper section finished in body colour (mirror foot in black), aspheric and blue-tinted.
□ **Exterior mirrors, with automatic anti-glare function**, incl. fold-in function and automatic parking function.



□ **Lights package** includes rear reading lights, rear footwell lights, indirectly lit door pockets and inside door handles, exit lights, and proximity illumination in the outside door handles. This ensures that the area around the door is evenly lit when the door is unlocked, making getting in and out easy and safe.



□ **Aluminium running boards** (105 mm wide) with rubber inserts give the BMW X5 a particularly sporting touch.



□ **Sun-insulating glass** for the rear side windows (behind the B-pillar) and rear window; these tinted windows reduce sun glare and ensure a pleasant temperature inside the car even in hot weather.



■ **Tailgate** splits horizontally in two; when open the lower section forms a platform taking loads up to 250 kg (e.g. for setting down heavy objects). The upper section can be opened separately (e.g. for quickly removing small items of luggage).
□ **Automatic tailgate operation**, electric.



■ **Roof spoiler**, upper section finished in body colour, giving the vehicle a particularly muscular look.



□ **Shadow Line, high-gloss**, covers window cavity cover and window frames, in high-gloss black.



■ **Brake Force Display with two-stage brake lights** makes it easier for drivers following from behind to see how hard you are applying the brakes: if you are applying the brakes in an emergency, the brake lights cover a larger area, allowing following traffic to distinguish between full application of the brakes and just a slight “tap” on the brakes. The result, clearly, is an even higher standard of driving safety on the road.

■ Standard equipment

□ Optional equipment



Front ornamental grille with titanium-coloured slats in the kidney grille and chrome surround (standard on the xDrive48i and xDrive35d). (Shown here in combination with the sports package).



Front ornamental grille with kidney slats painted black and chrome surround (standard on the xDrive30i and xDrive30d). (Shown here in combination with the Sports package).



Tailpipes: The exhaust system with two oval tailpipes is made of high-quality stainless steel, the rear ends are bordered with a chrome surround (standard on the xDrive48i).



Tailpipes: The xDrive30i, xDrive30d and xDrive35d models come with two single tailpipes. The exhaust system is made of high-quality stainless steel. The visible tailpipes are trimmed with a chrome surround.



□ **Trailer tow hitch** with removable towing head, incl. Trailer Stability Control (a special trailer system integrated in DSC and activated when the power socket is connected at the rear).
□ **Trailer load** can be optionally increased to 3,500 kg on a maximum gradient of 12% (available for the xDrive48i, xDrive30d and xDrive35d, xDrive30i: 2,700 kg).

■ Standard equipment

□ Optional equipment



■ BMW light-alloy wheels **star-spoke 209** with runflat tyres, 8.5 J x 18 inch, tyres 255/55 R 18 (standard on xDrive30i, xDrive30d and xDrive35d).



□ BMW light-alloy wheels **star-spoke 210** with runflat tyres, 8.5 J x 18 inch, tyres 255/55 R 18 (standard on xDrive48i).



□ BMW light-alloy wheels **Y-spoke 211** with runflat tyres, 9 J x 19 inch, tyres 255/50 R 19.



□ BMW light-alloy wheels **star-spoke 212** with runflat tyres, 9 J x 19 inch, tyres 255/50 R 19.



□ BMW light-alloy wheels **star-spoke 213** with mixed and runflat tyres, 9 J x 19 inch at the front on 255/50 R 19 tyres, 10 J x 19 inch at the rear on 285/45 R 19 tyres (available in conjunction with the Sports package).



□ BMW light-alloy wheels **Y-spoke 214** with mixed and runflat tyres, 10 J x 20 inch at the front on 275/40 R 20 tyres, 11 J x 20 inch at the rear on 315/35 R 20 tyres (available in conjunction with Sports package).

■ Standard equipment

□ Optional equipment



□ **Sports leather steering wheel**, three-spoke, incl. multifunction buttons for the steering wheel.



■ **Leather steering wheel with multifunction buttons** for cruise control and remote control of the radio/telephone. Two buttons are freely programmable.

□ **Active steering incl. Servotronic** adapts the steering transmission and steering force to the current speed of the vehicle, thus ensuring optimum steering precision, agility and comfort.



■ **Start/Stop button** for starting the engine. After inserting the ignition key you can start or stop the engine by pressing the button.



□ **Voice control system**; for adjusting e.g. radio station, navigation routes while driving. Functions are shown on the Control Display at the same time (this feature is included in the optional navigation system Professional*).



□ **Steering wheel heating**: Just press a button to quickly warm up the steering wheel rim – a particularly pleasant amenity in winter.

■ Standard equipment

□ Optional equipment



■ **Controller** is the central iDrive input element (for driver and passenger). Additional functions can be activated from the control display using this rotary/push button. Menu navigation is based on the points of the compass. Four different menus are available: Climate, Communication, Navigation, Entertainment and on-board info (optional navigation).



■ **Control Display** with TFT screen (6.5 inch, colour). Shows the functions activated by the Controller (e.g. on-board computer or radio). In conjunction with the optional navigation system Professional* or with the TV function, the screen measures 8.8 inches.



■ **Functional bookmarks:** With these buttons, the driver and passenger can save their most frequently used navigation, audio (e.g. certain radio stations or CD tracks) or telephone functions on eight separate buttons for rapid access.



□ **Navigation system Professional*** with colour 8.8 inch display, traffic guidance provided by voice, arrows and street maps. The split-screen function allows you to view radio and navigation data simultaneously.



□ **TV function** allows you to use the Control Display as a television when the vehicle is stationary. Both analogue and digital (DVB-T) channels broadcast by terrestrial stations can be received.



□ **Rear view camera** clearly shows the area behind the vehicle on the Control Display, where interactive road line markings show for example, whether the target parking space is large enough for the vehicle. The rear view camera is activated automatically when the reverse gear is selected.



□ **Park Distance Control (PDC)**, front and rear, makes parking and manoeuvring easier in the narrowest spaces; the distance between the vehicle and the nearest obstacle is indicated acoustically as well as visually in the Control Display.



□ **Auxiliary heating with remote control**, ideal in winter and in cold weather. When you step into your vehicle, the windscreen is already free of ice and the interior is already pleasantly warm.

* Not available in all countries. Please consult your BMW partner.

■ Standard equipment

□ Optional equipment



■ **Cruise control with brake function** facilitates comfortable driving at a pre-selected speed (from about 30 km/h).



■ **Six-speed automatic transmission with Steptronic.** Gears are shifted very quickly and smoothly for optimum performance on the road.



■ **Parking brake with Auto-Hold-function,** allowing you to hold and release the vehicle conveniently by means of a button in the central console.



■ **Cupholders (two)** in the front central console.



■ **Armrest, front** on the tunnel console, can be positioned separately for driver and passenger, with storage compartment.



■ **Storage options** for a wide range of items are available in the central console, in the front and rear doors and in a stow-away tray in the rear on the right.

■ **AUX-IN connection** for an external audio source, e.g. for an MP3 player.



■ **Radio BMW Professional,** 4-channel amplifier, 2-tuner reception, antenna diversity, scan function, CD player, MP3 decoder, 6 loudspeakers.

□ **DAB tuner** for additional reception of digital radio broadcasts.

□ **USB/audio interface** in the storage compartment under the front armrest for connecting a USB stick or external audio sources such as an iPod.



□ **HiFi System Professional** with a 600 watt digital amplifier and 16 loudspeakers guarantees a high-intensity audio experience at every seat.

□ **HiFi System** with digital amplifier (205 watt) and 12 loudspeakers, as well as digital equalising which adapts the sound optimally to the shape of the vehicle interior.

■ Standard equipment

□ Optional equipment



□ **CD changer**, 6-disc single slot changer, with features including scan function, random play and MP3 decoder; installed in the glove compartment.
□ **DVD changer**, 6-disc, supports, multi-channel audio DVDs.



■ **Automatic air conditioning**, incl. microfilter, to provide an ideal climate at any season, automatic temperature and air volume control, vent programme and rear ventilation; settings displayed on Control Display (standard on the xDrive30i and xDrive30d).



□ **2-zone automatic air conditioning**, incl. Automatic Air Recirculation (AAR) with circulation filter, sun and condensation filters, automatic temperature control (separate for driver and passenger) as well as air volume control; display and settings on the Control Display (standard on the xDrive48i and xDrive35d).



□ **4-zone automatic air conditioning**. As for 2-zone air conditioning, plus the climate in the rear area of the vehicle can be separately controlled with two dials and a display. This feature also includes rear blowers, footspace heaters and outlets on the B-pillars.



□ **Preparation for mobile telephone with Bluetooth interface**, incl. hands-free installation with snap-in adapter (Original BMW Accessory) for a wireless Bluetooth mobile phone and iPhone connection which can be operated via the multifunction buttons on the steering wheel, iDrive Controller or the voice control system. Includes sockets for charger and antenna. Your BMW partner will be happy to inform you about recommended telephones.



□ **Head-up Display** shows relevant information, for example current speed, directly in the driver's field of vision. Arrow directions for navigation, for example, can also be shown. Height and brightness of the display can be individually adjusted, so that the driver can fully concentrate on the traffic at all times.

■ Standard equipment

□ Optional equipment

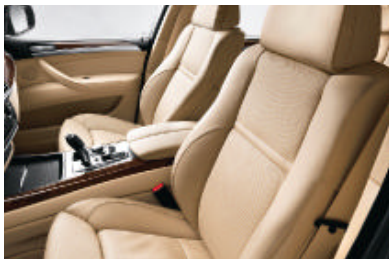

□ **Comfort seats** for driver and passenger (shown here with active seat ventilation, which is only available in conjunction with Nevada leather, perforated) with electrical seat adjustment for all seat levels. Further electronic functions include the upper seat back and seat depth adjustment and height adjustment.

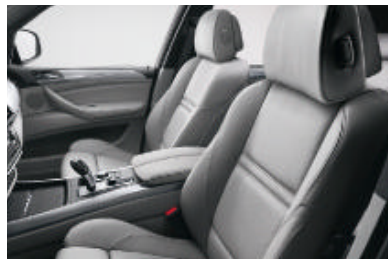

□ **Sports seats** for driver and passenger, highly contoured seat sides for optimal lateral support at all times. Seat height, seat angle and backrest angle are electrically adjustable, thigh support manually adjustable.



■ **Standard seats**, with manual adjustment forward/back, seat adjustment for headrest height and angle, as well as electrical adjustment for seat height and backrest angle.



□ **Lumbar support** on driver's and front passenger's seats, electrically height- and width- adjustable to provide a perfectly ergonomic seating position and support your back muscles.



□ **Seat adjustment, electric**, of driver's and front passenger's seats, with memory function for driver's seat, steering column and exterior mirrors, including easy access (standard on the xDrive48i and xDrive35d).



□ **Seat heating for driver and front passenger:** seat surfaces and backrests with heating in three stages for pleasant temperatures shortly after setting off.



□ **Active seat ventilation** provides a noticeably more comfortable ride. Fans in the seat base and backrest blow air through the seat covers (available for the driver and front passenger in conjunction with Nevada leather, perforated and comfort seats).
□ **Active seats for driver and front passenger** provide a relaxed seating and driving position. The seat moves up and down on either side, cyclically mobilising the pelvis and lumbar spine (available in conjunction with comfort seats).



□ **Interior mirror and exterior mirror**, with automatic anti-glare function which activates once a certain light intensity from following vehicles is reached. With fold-in function for exterior mirror.
□ **Alarm system with remote control:** In any attempt to break into and manipulate your car, the alarm system sets off a loud signal and immediately switches on the hazard warning flashers.

■ Standard equipment

□ Optional equipment



□ **BMW Individual instrument panel** in sophisticated leather, for a particularly exclusive interior atmosphere.



□ **Panorama glass roof** with an extra-large opening and a transparent viewing area, plus speed-sensitive wind deflector. Both glass panels tilt up electrically at the touch of a button and the front panel also comes with a sliding function, an electrically operated roofliner (protecting you and your passengers from glare) as well as comfort opening/closing complete with trap release.



□ **Roofliner** in Anthracite; the A-, B-, C- and D-pillar trim as well as the sun visors and roof grab handles are finished in refined Black (included in Sports Package).

■ Standard equipment

□ Optional equipment



■ **Rear seat back rest**, can be split (60 : 40) asymmetrically and individually folded down.



□ **Third row of seating**¹ facilitates a flexible use of the available space. The two additional seats face forward, and can be separately folded down. This option includes additional heating for the third row footspace. (Option for xDrive30i, xDrive30d and xDrive35d incl. level adjustment with air suspension on the rear axle).



■ **Luggage compartment partition net** behind the second row of seating, ensures that objects in the luggage compartment cannot fall forward into the passenger compartment.



□ **Adaptive fastening system** for safely stowing luggage of different sizes (available in conjunction with the storage package).



□ **Storage package** including an illuminated storage box under the front central console with a 12-V socket, two lashing rails with four lashing points in the luggage compartment, storage net left, multifunction hooks left and right (in conjunction with third row of seating, storage net under armrest and no multifunction hooks left and right).

¹ Not in combination with cloth upholstery.

■ Standard equipment

□ Optional equipment



■ **Sockets (12-V)**, one in the front storage bowl, one in the rear central console and one in the luggage compartment.



□ **DVD system** in the rear offers an independently controllable DVD player with a fold-down 8-inch screen. The system can be operated by wireless remote control, has sockets for two headphones and a video camera, and is compatible with infra-red headphones. In conjunction with the TV function, the same TV programme can be viewed simultaneously on the front (at a standstill) and rear screens.



■ **Cupholders** integrated in the rear centre armrest.



□ **Seat heating at the rear:** Same as the electric heating of the driver's and front passenger's seats, with heating in two stages, available in conjunction with leather upholstery.



□ **Ski bag** for clean and safe transport of up to four pairs of skis with up to four occupants in the car; whenever the ski bag is not required, it remains stored conveniently out of sight behind the centre armrest.



□ **Sunblinds:** manual sunblinds on each rear side window for reliable protection from intense sun glare.



□ **Comfort access** for opening and locking the vehicle without holding the remote control. The engine can also be started without the key using the start/stop button

■ **Central locking** for the doors, fuel cap, incl. electronic immobiliser and remote control with automatically recharging key battery.

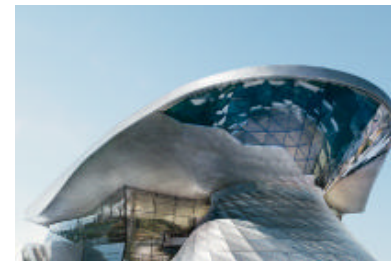

□ **BMW Welt:** Taking delivery of a car has always ranked among the best moments for any car driver. Now that moment can become a truly unforgettable day – at the new BMW Welt, the experience and delivery centre in Munich, Germany. Visit the Museum, tour the plant or explore the Technology studio: BMW Welt brings you the true fascination of BMW. Experience more online at www.bmw-welt.com

□ Optional equipment

□ **Sports package:** lends the powerful BMW X5 a more dynamic air, with features including BMW light-alloy wheels, star-spoke 213 with mixed tyres, Shadow Line, ventilation grille in a contrasting colour, and highly responsive suspension settings. The interior boasts sports seats for driver and front passenger with electronic seat adjustment, sports leather steering wheel and Anthracite roofliner.



Sports leather steering wheel, incl. multifunction buttons, three-spoke. The heftier steering rim affords excellent grip.

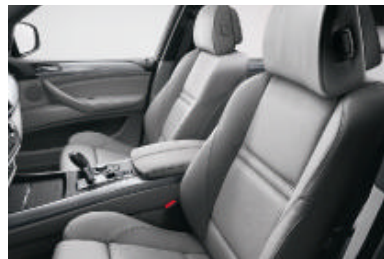

Sports seats for driver and passenger, highly contoured seat sides for optimal lateral support at all times. Seat height, seat angle and backrest angle are electrically adjustable, thigh support manually adjustable.



Ventilation grilles under the double kidney grille and in the bumper are in a contrasting colour.



BMW light-alloy wheels **star-spoke 213** with mixed and runflat tyres, 9 J x 19 inch at the front on 255/50 R19 tyres, 10 J x 19 inch at the rear on 285/45 R19 tyres.



□ BMW light-alloy wheels **Y-spoke 214** with mixed and runflat tyres, 10 J x 20 inch at the front on 275/40 R20 tyres, 11 J x 20 inch at the rear on 315/35 R20 tyres.



Shadow Line, high-gloss includes window cavity cover and window frame surrounds in high-gloss black.



Roofliner in Anthracite, sun blinds and roof handles are implemented in refined black.



M leather steering wheel, sports seats in exclusive Nappa leather, light-alloy wheels V-spoke 227 M (20 inch).

Athletics plus aesthetics: the M sports package.

Exclusive, stylish – and unmistakably powerful: the M sports package makes a particularly strong impression. The dynamic appearance is perfected by widened wheel arches and an exterior in metallic Carbon Black, pictured here and exclusive to the M sports package. Everything is polished to perfection in body colour, from the bumper and running boards to the door sills. Five other exterior colours are available in addition to Carbon Black. A sporty look is accentuated even further by the light-alloy wheels V-spoke 223 M with mixed tyres, 9 J x 19 inch with 255/50 R 19 tyres at the front, 10 J x 19 inch with 285/45 R 19 tyres at the rear (pictured here). Or you could opt for the

light-alloy wheels V-spoke 227 M, 10 J x 20 inch with 275/40 R 20 tyres at the front, 11 J x 20 inch with 315/35 R 20 tyres at the rear. Making sure you enjoy the utmost in comfort with every bend you take, the M sports package has sports seats – in optional exclusive Nappa leather Black. The driver and front passenger seats have an electric seat adjustment feature; the driver's seat comes with a memory function. Further features of the M sports package are the BMW Individual roof rails, Shadow Line, a roofliner in Anthracite and interior trim in Brushed Aluminium.

■ Standard equipment □ Optional equipment — Not available

Safety	xDrive30i	xDrive48i	xDrive30d	xDrive35d
Active headrests in the front	■	■	■	■
Airbags:				
– Driver and front passenger airbags (with seat occupancy detector)	■	■	■	■
– Head airbags (for front and 2nd-row passengers)	■	■	■	■
– Side airbag for driver and front passenger, integrated into seat	■	■	■	■
Alarm system	□	□	□	□
Brake force display	■	■	■	■
Brakes:				
– Disc brakes at the front, inner-vented	■	■	■	■
– Disc brakes at the rear, inner-vented	■	■	■	■
Central locking with electronic immobiliser , crash sensor	■	■	■	■
Child seat fastening ISOFIX in the rear	■	■	■	■
Dynamic Stability Control (DSC) (DSC, incl. ABS, CBC and traction control DTC) with additional functions	■	■	■	■
Hill Descent Control (HDC)	■	■	■	■
Parking brake , electromechanical, with Auto-Hold function	■	■	■	■
Rollover sensor	■	■	■	■
Seat belts:				
– Ergonomic belt system at the rear with 3-point seat belts for all seats	■	■	■	■
– Inertia-reel seat belts with pyrotechnical belt tensioner and belt force governor	■	■	■	■
Safety body shell:				
– Bumper system with impact cushions in aluminium at the front and steel at the rear; bumpers regenerate to their original shape in collisions at up to 4 km/h, deformation elements front and rear at up to 15 km/h	■	■	■	■
– Door-integrated side impact protection	■	■	■	■

Exterior design	xDrive30i	xDrive48i	xDrive30d	xDrive35d
Aluminium running boards	□	□	□	□
Double kidney grille with kidney slats in Black (Titanium coloured on xDrive48i and xDrive35d) and chrome surround	■	■	■	■
Exterior mirrors in body colour , tinted, electrically adjustable, aspherical and heated	■	■	■	■
Metallic paint	□	□	□	□
Roof railing , satin Aluminium	□	□	□	□
Roof railing , black, matt	□	□	□	□
Shadow Line , high-gloss	□	□	□	□

Equipment packages	xDrive30i	xDrive48i	xDrive30d	xDrive35d
M Sports package (with sports suspension settings, M exterior parts, sports seats, light-alloy wheels, V-spoke 223M with mixed tyres, M leather steering wheel and Individual roofliner in Anthracite, etc.)	□	□	□	□
Sports package (incl. sports suspension settings, sport seats, light-alloy wheels star-spoke 213 with mixed tyres and roofliner in Anthracite)	□	□	□	□

Standard equipment
 Optional equipment
 — Not available

Wheels	xDrive30i	xDrive48i	xDrive30d	xDrive35d
Runflat indicator and runflat tyres	■	■	■	■
Wheels:				
– Light-alloy wheels star-spoke 209, 8.5 J x 18-inch, 255/55 R 18 runflat tyres	■	□	■	■
– Light-alloy wheels star-spoke 210, 8.5 J x 18-inch, 255/55 R 18 runflat tyres	□	■	□	□
– Light-alloy wheels star-spoke 212, 9 J x 19-inch, 255/50 R 19 runflat tyres	□	□	□	□
– Light-alloy wheels Y-spoke 211, 9 J x 19-inch, 255/50 R 19 runflat tyres	□	□	□	□
– Light-alloy wheels star-spoke 213 with mixed tyres, 9 J x 19-inch with 255/50 R 19 runflat tyres at the front, 10 J x 19-inch with 285/45 R 19 runflat tyres at the rear (only in combination with sports package)	□	□	□	□
– Light-alloy wheels V-spoke 223 M with mixed tyres, 9 J x 19-inch with 255/50 R 19 runflat tyres at the front, 10 J x 19-inch, with 285/45 R 19 runflat tyres at the rear (only in combination with M sports package)	□	□	□	□
– Light-alloy wheels Y-spoke 214 with mixed tyres, 10 J x 20-inch with 275/40 R 20 runflat tyres at the front, 11 J x 20-inch with 315/35 R 20 runflat tyres at the rear (only in combination with sports package)	□	□	□	□
– Light-alloy wheels V-spoke 227 M with mixed tyres, 10 J x 20-inch with 275/40 R 20 runflat tyres at the front, 11 J x 20-inch with 315/35 R 20 runflat tyres at the rear (only in combination with M sports package)	□	□	□	□

Interior design	xDrive30i	xDrive48i	xDrive30d	xDrive35d
BMW Individual instrument panel , in leather	□	□	□	□
Instrument panel with circular speedometer and rev counter, plus tank level and fuel consumption gauges	■	■	■	■
Interior trims:				
– Graphitane, matt	■	–	■	–
– Fine-wood trim Burr Walnut, dark	□	■	□	■
– Brushed Aluminium, fine grain	□	□	□	□
– Fine-wood trim Bamboo Grain, dark	□	□	□	□
– Fine-wood trim Poplar Grain, light	□	□	□	□
Roofliner in Anthracite	□	□	□	□
Upholstery:				
– Twill Cloth	■	■	■	■
– Exclusive Nappa leather, extended	□	□	□	□
– Nevada leather	□	□	□	□
– Nevada leather, perforated (only in combination with active seat ventilation)	□	□	□	□

■ Standard equipment □ Optional equipment — Not available

Transmission and technology	xDrive30i	xDrive48i	xDrive30d	xDrive35d
6-cylinder in-line diesel engine with four-valve technology	—	—	■	■
6-cylinder in-line petrol engine with four-valve technology	■	—	—	—
8-cylinder V petrol engine with four-valve technology	—	■	—	—
6-speed automatic transmission with Steptronic	■	■	■	■
Active Steering incl. Servotronic	□	□	□	□
Adaptive Drive (Dynamic Drive and EDC)	□	□	□	□
Brake Energy Regeneration	■	■	■	■
Common Rail Technology	—	—	■	■
Diesel particle filter	—	—	■	■
Double-joint spring strut front axle	■	■	■	■
Double-VANOS, double variable camshaft control	■	■	—	—
Emissions standard: EU4 ¹	■	■	■	■
Multilink rear axle	■	■	■	■
Self-levelling with pneumatic rear suspension	□	■	□	□
Sports suspension settings	□	□	□	□
Turbo charger with variable turbine geometry	—	—	■	—
Valvetronic, fully variable valve control	■	■	—	—
Variable Twin Turbo	—	—	—	■
xDrive (all-wheel drive system with variable torque distribution)	■	■	■	■

Driver assistance	xDrive30i	xDrive48i	xDrive30d	xDrive35d
Cruise Control with braking function	■	■	■	■
Head-up Display	□	□	□	□
High-beam assistant	□	□	□	□
Park Distance Control (PDC), front and rear	□	□	□	□
Rear view camera	□	□	□	□

Light and sight	xDrive30i	xDrive48i	xDrive30d	xDrive35d
Adaptive Headlights with variable light distribution incl. turning lights	□	□	□	□
Exterior mirrors with automatic anti-glare function, incl. fold-in function and automatic parking function	□	□	□	□
Fog lights with free-form reflector incl. heated front windscreen washer nozzles and exterior mirrors	■	■	■	■
Headlight washing system	□	□	□	□
Interior mirror with automatic anti-glare function	■	■	■	■

¹ The X5 xDrive30d and xDrive35d fulfil emissions standard EU4 (N1-G3).

Standard equipment
 Optional equipment
 Not available

Light and sight	xDrive30i	xDrive48i	xDrive30d	xDrive35d
Lights package (incl. vicinity lights integrated in exterior door handles, door trim and interior door handle lighting, rear reading lights and rear footwell illumination)	<input type="checkbox"/>	<input type="checkbox"/>	<input type="checkbox"/>	<input type="checkbox"/>
Rain sensor , incl. automatic driving lights control	<input type="checkbox"/>	<input type="checkbox"/>	<input type="checkbox"/>	<input type="checkbox"/>
Xenon Headlights for high and low beam incl. automatic headlight range control and four light rings (daytime driving and parking lights)	<input type="checkbox"/>	<input checked="" type="checkbox"/>	<input type="checkbox"/>	<input checked="" type="checkbox"/>

Interior equipment	xDrive30i	xDrive48i	xDrive30d	xDrive35d
Automatic air conditioning	<input checked="" type="checkbox"/>	<input type="checkbox"/>	<input checked="" type="checkbox"/>	<input type="checkbox"/>
Automatic air conditioning, 2-zone (incl. AAR, condensation and solar sensors and residual heat function) with air outlets in the rear	<input type="checkbox"/>	<input checked="" type="checkbox"/>	<input type="checkbox"/>	<input checked="" type="checkbox"/>
Automatic air conditioning, 4-zone (with separate temperature control in the rear)	<input type="checkbox"/>	<input type="checkbox"/>	<input type="checkbox"/>	<input type="checkbox"/>
Auxiliary heating	<input type="checkbox"/>	<input type="checkbox"/>	<input type="checkbox"/>	<input type="checkbox"/>
Climate comfort windscreen	<input type="checkbox"/>	<input type="checkbox"/>	<input type="checkbox"/>	<input type="checkbox"/>
Seats/seat comfort:				
– 3rd row of seats (two separate folding seats, with additional heating)	<input type="checkbox"/>	<input type="checkbox"/>	<input type="checkbox"/>	<input type="checkbox"/>
– Active seats for driver and passenger	<input type="checkbox"/>	<input type="checkbox"/>	<input type="checkbox"/>	<input type="checkbox"/>
– Comfort seats for driver and passenger, electric seat adjustment with additional functions incl. lumbar support	<input type="checkbox"/>	<input type="checkbox"/>	<input type="checkbox"/>	<input type="checkbox"/>
– Lumbar support for driver and front passenger, electrically adjustable	<input type="checkbox"/>	<input type="checkbox"/>	<input type="checkbox"/>	<input type="checkbox"/>
– Rear seats, asymmetrically foldable (60:40)	<input checked="" type="checkbox"/>	<input checked="" type="checkbox"/>	<input checked="" type="checkbox"/>	<input checked="" type="checkbox"/>
– Seat adjustment, electric (with memory function for driver's seat and exterior mirrors, for xDrive48i and xDrive35d in conjunction with standard seat)	<input type="checkbox"/>	<input checked="" type="checkbox"/>	<input type="checkbox"/>	<input checked="" type="checkbox"/>
– Seat adjustment, partially electric	<input checked="" type="checkbox"/>	<input checked="" type="checkbox"/>	<input checked="" type="checkbox"/>	<input checked="" type="checkbox"/>
– Seat heating for driver and front passenger	<input type="checkbox"/>	<input type="checkbox"/>	<input type="checkbox"/>	<input type="checkbox"/>
– Seat heating in the rear	<input type="checkbox"/>	<input type="checkbox"/>	<input type="checkbox"/>	<input type="checkbox"/>
– Sports seats for driver and front passenger (incl. electric seat adjustment)	<input type="checkbox"/>	<input type="checkbox"/>	<input type="checkbox"/>	<input type="checkbox"/>
Steering wheel heating	<input type="checkbox"/>	<input type="checkbox"/>	<input type="checkbox"/>	<input type="checkbox"/>
Steering wheels:				
– Leather steering wheel, three-spoke, multifunction	<input checked="" type="checkbox"/>	<input checked="" type="checkbox"/>	<input checked="" type="checkbox"/>	<input checked="" type="checkbox"/>
– Sports leather steering wheel, three-spoke, multifunction	<input type="checkbox"/>	<input type="checkbox"/>	<input type="checkbox"/>	<input type="checkbox"/>
Sun blinds for rear windscreen and for rear side windows	<input type="checkbox"/>	<input type="checkbox"/>	<input type="checkbox"/>	<input type="checkbox"/>
Windscreen with grey shade band	<input type="checkbox"/>	<input type="checkbox"/>	<input type="checkbox"/>	<input type="checkbox"/>

■ Standard equipment □ Optional equipment — Not available

Comfort and interior equipment	xDrive30i	xDrive48i	xDrive30d	xDrive35d
Adaptive fastening system	□	□	□	□
Automatic tailgate operation	□	□	□	□
Comfort access system (for keyless entry and engine start)	□	□	□	□
Cupholders front and rear	■	■	■	■
Panoramic glass roof, electric, tilt/slide functions, convenient operation via vehicle key	□	□	□	□
Start/Stop button	■	■	■	■
Storage facilities with anti-slip lining in the doors, front, centre console, storage box in luggage compartment (lockable)	■	■	■	■
Storage package (incl. 12-V socket, net and cargo rails in luggage compartment)	□	□	□	□
Tailgate, split	■	■	■	■
Window lifts, electrical, with one-touch control, comfort switch and trap release	■	■	■	■

Entertainment and communication	xDrive30i	xDrive48i	xDrive30d	xDrive35d
BMW ConnectedDrive – Telematics Services*:				
– BMW Assist	□	□	□	□
– BMW Online	□	□	□	□
– BMW TeleServices	□	□	□	□
Control display	■	■	■	■
Controller	■	■	■	■
Functional bookmarks	■	■	■	■
Navigation system Professional* with 8.8 inch colour monitor, arrow and map display, CD and DVD drive	□	□	□	□
Navigation system Professional*, with integrated preparation for Bluetooth mobile phone, (incl. voice control, BMW Assist* and BMW Online*)	□	□	□	□
Preparation for mobile phone Business with Bluetooth interface, including comfort connection for mobile phone music player, BMW Assist*	□	□	□	□
Radio/audio:				
– AUX-IN connection in centre console	■	■	■	■
– CD changer for six CDs, in glove compartment	□	□	□	□
– DAB tuner	□	□	□	□
– DVD changer in the glove compartment, with multi-channel audio system	□	□	□	□
– DVD system in the rear	□	□	□	□
– HiFi loudspeaker system	□	□	□	□
– HiFi system Professional	□	□	□	□
– Radio BMW Professional, incl. MP3-compatible CD drive	■	■	■	■
– USB/audio interface	□	□	□	□
TV function	□	□	□	□

* Not available in all countries. Please consult your BMW partner.

Technical data		xDrive30i	xDrive48i	xDrive30d	xDrive35d
Weight					
Unladen EU ¹	kg	2075	2180	2150	2185
Max. permissible	kg	2680	2785	2755	2790
Permitted load	kg	680	680	680	680
Permitted axle load, front/rear	kg	1245/1535	1345/1540	1295/1545	1335/1555
Permitted roof load	kg	100	100	100	100
Permitted trailer load, unbraked	kg	750	750	750	750
Permitted trailer load, braked, max 12% gradient	kg	2700	2700 (3500) ⁴	2700 (3500) ⁴	2700 (3500) ⁴
Permitted trailer load, braked, max 8% gradient	kg	2700	2700 (3500) ⁴	2700 (3500) ⁴	2700 (3500) ⁴
Engine²					
Cylinder/valves		6/4	8/4	6/4	6/4
Capacity	cc	2996	4799	2993	2993
Max. output/engine speed	kW (hp) rpm	200 (272) 6650	261 (355) 6300	173 (235) 4000	210 (286) 4400
Max. torque/engine speed	Nm rpm	315 2750	475 3400–3800	520 2000–2750	580 1.750–2250
Transmission					
Standard transmission ratios					
	I/II:1	4.17/2.34	4.17/2.34	4.17/2.34	4.17/2.34
	III/IV:1	1.52/1.14	1.52/1.14	1.52/1.14	1.52/1.14
	V/VI/R:1	0.87/0.69/3.40	0.87/0.69/3.40	0.87/0.69/3.40	0.87/0.69/3.40
Final drive ratio	:1	4.44	3.91	3.64	3.64
Performance					
Top speed	km/h	210	240	210	235
Acceleration 0–100 km/h	s	8.1	6.5	8.1	7.0
Fuel consumption³					
Urban	l/100 km	13.7	16.9	10.2	10.3
Extra-urban	l/100 km	8.2	9.2	6.9	7.0
Composite	l/100 km	10.2	12.0	8.1	8.2
CO ₂ emissions	g/km	244	286	214	216
Tank capacity, approx.	l	85	85	85	85
Wheels					
Tyre dimensions		255/55 R18	255/55 R18	255/55 R18	255/55 R 18
Wheel dimensions		8.5J x 18	8.5J x 18	8.5J x 18	8.5 J x 18
Material		Light-alloy	Light-alloy	Light-alloy	Light-alloy

¹ The figure quoted includes a 90 per cent tank filling, 68 kg for the driver and 7 kg for luggage. Unladen weight applies to vehicles with standard specification. Optional equipment may increase this figure.

² The petrol engines are designed for RON 98 fuel. They may also be run on RON 91 with a decrease in power output.

³ All engines meet the EU4 (N1) emissions standard. The X5 xDrive30d and xDrive35d comply with emission standard EU4 (N1-G3). Fuel consumption is determined in accordance with the ECE driving cycle made up of approximately one third urban and two thirds extra-urban driving (based, on the distance covered). CO₂ emissions are measured in addition to fuel consumption. Fuel consumption is determined for vehicles with standard equipment. Optional equipment (such as wider tyres) can have a significant impact on fuel consumption and on performance.

⁴ Increased trailer load in conjunction with optional equipment.

The BMW X5 xDrive48i shown in this brochure has the exterior colour Space Grey metallic. The upholstery is in Exclusive Nappa leather Beige, extended coverage, with interior trim in fine wood Burr Walnut.

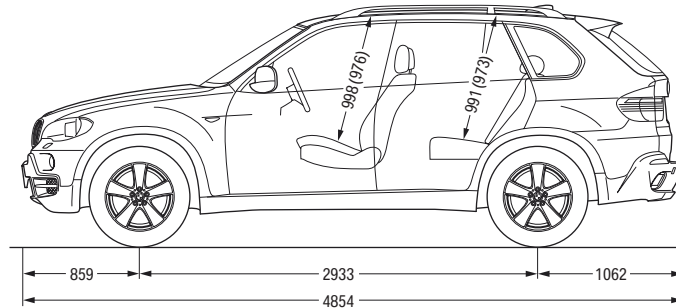
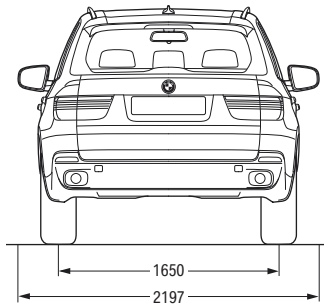
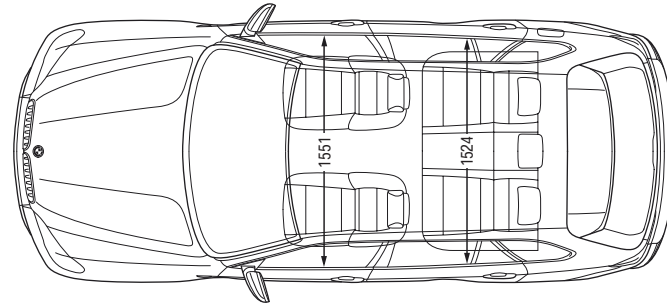
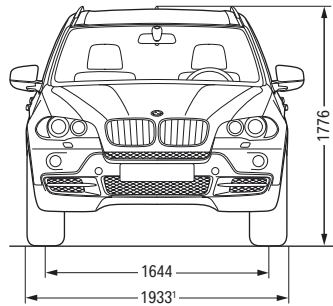

All dimensions of the technical drawings in millimetres. Luggage compartment capacity (VDA method) 620 –1750 litres.
 *Width with folded-in exterior mirrors. Values in () are for vehicles with a panoramic glass roof.

BMW Recycling.

Your BMW is the product of a comprehensive recycling concept. But what exactly does that mean in practice? It means that all the requirements of recycling are taken into account from the start, in the initial development of a BMW. One example is careful material selection designed to preserve resources and to ensure efficient recycling compatible with the environment. Each BMW is designed and built for simple and economic recycling after its long running life. Since 1994, we have been collecting the know-how required for this purpose at the unique BMW Recycling and Dismantling Centre (RDC) near Munich. At the same time, the BMW Group is establishing a complete network of vehicle recycling facilities within Europe, focusing in the process on the high standards of quality and environmental care that BMW is renowned for. Please contact your BMW partner on all matters regarding your end-of-life vehicle. He will be happy to help.

The models illustrated in this brochure show the specifications for the German market. In part, they include optional equipment and accessories not fitted as standard. According to the specific requirements of other markets, alterations in models, standard and optional equipment, as described in this brochure, may occur. For precise information please contact your local dealership. Subject to change in design and equipment.

© BMW AG, Munich/Germany. Not to be reproduced wholly or in part without written permission of BMW AG, Munich.

BMW recommends Castrol

More about BMW

www.bmw.com



Sheer
Driving Pleasure

